



# Nitrilium<sup>+</sup>

Latex Free | Powder Free | Non sterile | Textured | Ambidextrous



Ördem ÇAAK

**New York  
Microscope  
Company**  
Microscope Experts since 1979

100 Lauman Lane, Suite A, Hicksville, NY 11801  
Tel: (877) 877-7274 | Fax: (516) 801-2046  
Email: [Info@nyscopes.com](mailto:Info@nyscopes.com)  
[www.microscopeinternational.com](http://www.microscopeinternational.com)



## + FEATURES

- Ambidextrous
- Made from 100% nitrile
- No plasticizers, esters, silicone oil, or powder.
- High degree of comfort, elasticity, acid and alkali resistance, oil resistance, and bacteria resistance.

## + RECOMMENDED USE



## + CERTIFICATES





EN ISO 13485:2012



EN ISO 13485:2012/AC:2012



GB/4806.11-2016



## PRODUCT INFORMATION & SPECIFICATIONS

Product Code	-	HWM01
Product Description	-	Nitrile, Powder Free, Non-Sterile, Fingertip Textured
Colour	-	Blue
Material	-	100% nitrile examination gloves
Packing Method	-	100 pcs per box by weight 10 boxes per carton

## Specifications

### Glove Length (mm)

Length (mm)	≥ 250
-------------	-------

### Glove Size (Palm Width) mm

Small	86 ± 4
Medium	98 ± 4
Large	107 ± 4
Extra Large	115 ± 4

### Thickness Measurements mm

Palm (Centre of Palm)	0.10 ± 0.02
Finger (13mm±3mm from tip)	0.13 ± 0.02

### Physical Properties

	Before Ageing	After Ageing
Tensile Strength (N)	≥ 7	≥ 7
Elongation (%)	730	550

### Inspection Levels & AQL

	Inspection Level	AQL
Watertightness	G1	1.50
Physical Dimensions	S2	4.00
Tensile Strength	S2	4.00
Visual Inspection (Major)	S4	2.50
Visual Inspection (Minor)	S4	4.00



# Nitrilium



EN ISO 13485:2012



EN ISO 13485:2012/AC:2012



GB/4806.11-2016



## DIMENSIONS AND PACKAGING

### BOX DIMENSIONS AND WEIGHT

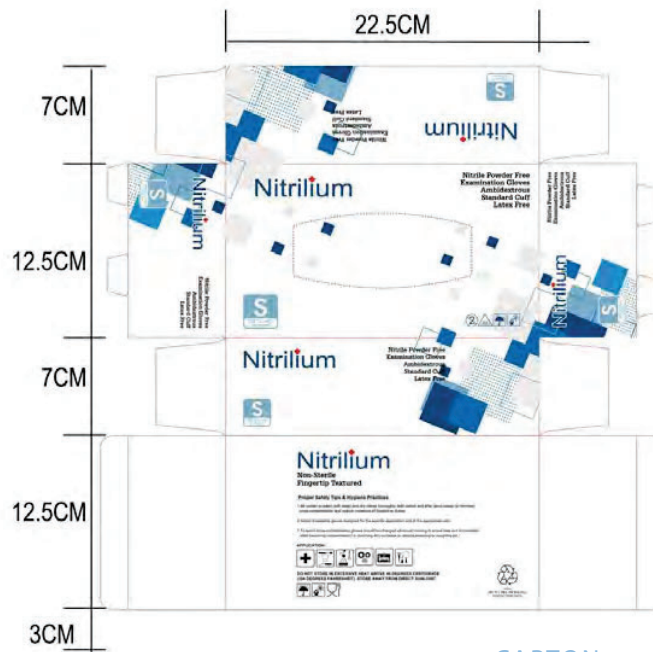

### CARTON DIMENSIONS AND WEIGHT

### WEIGHT PER BOX

<b>S</b>	<b>M</b>	<b>L</b>	<b>XL</b>
300g	350g	400g	450g

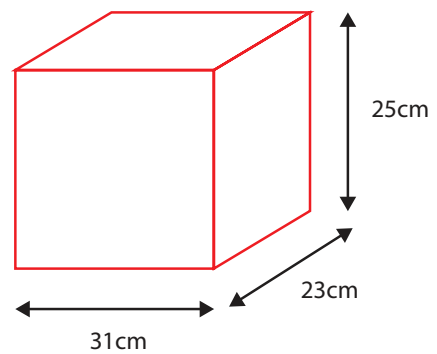

### WEIGHT PER CARTON

<b>S</b>	<b>M</b>	<b>L</b>	<b>XL</b>
3000g	3500g	4000g	4500g

1,000 Units (10 Boxes per carton)

